



D-MAX AT35

This is no ordinary pick-up. Inspired by the harshest and most extreme conditions on earth, the all-new Isuzu D-Max AT35, created in partnership with Arctic Trucks, is the culmination of over 30 years of continual development and deployment of vehicles built for purpose. Designed to perform both on and off-road, this exceptional vehicle is professionally re-engineered by Arctic Trucks technicians to incorporate significant enhancements to the body, frame, suspension, wheels, tyres and more.

CONTACT DEALER FOR PRICING

ISUZU

Building on the renowned qualities of Isuzu's popular D-Max platform, the AT35 version is as capable as it is unique. Developed by Arctic Trucks' experienced team of off-road mobility specialists, it tackles rugged and challenging terrains with ease, without compromising overall payload or towing capacity.

Combined with extensive adjustment, strengthening and reprofiling of the chassis, body and bodywork, the specially developed Arctic Trucks Bilstein performance suspension system and enlarged all-terrain wheel and tyre package deliver a balance of confidence-inspiring on-road handling and enhanced clearance, comfort, control and mobility over all terrains.

The iconic Arctic Trucks widened flares create coverage and protection, while amplifying the vehicle's rugged stance. This is complemented by premium Arctic Trucks and AT35 badging and detailing throughout, together with durable extended Arctic Trucks side steps, mud guards, interior mats and a versatile 2" rear receiver hitch, enabling quick, easy fitment of tow balls, winches, steps, gear carriers and much more.

All elements of each D-Max AT35 build are undertaken in Arctic Trucks' own Isuzu-approved facilities to ensure showroom quality, adherence to all relevant vehicle type approvals and full warranty alignment.

CORE SPECIFICATION*

- Extensive Arctic Trucks re-engineering to frame, inner arches, body and bodywork
- Widened Arctic Trucks fender flares (body colour), featuring recessed AT tyre pressure detail
- Rugged 17x10 Arctic Trucks alloys (matte black)**
- 35" (LT315/70 R17) BFGoodrich KO2 All-Terrain tyres
- Optimised and elevated Arctic Trucks Bilstein performance suspension system, featuring front springs/dampers and rear dampers with additional front/rear body lift (elevation: +40mm)
- Arctic Trucks speedometer re-calibration
- Robust extended profile Arctic Trucks side steps
- Arctic Trucks rear height bar with 2" multifunction receiver hitch
- Enlarged and strengthened Arctic Trucks mud guards
- Arctic Trucks / AT35 badging and detailing package (flares, front wings, side steps, tailgate, wheel centres, mud guards, receiver cover, headrests, sill guards)
- Arctic Trucks premium car mats (anthracite and grey)
- Arctic Trucks locking wheel nuts and torque wrench
- Arctic Trucks D-Max AT35 user manual, Certificate of Authenticity and 30th anniversary decal



WEIGHTS & DIMENSIONS*

Gross Vehicle Weight	3,250 kg
Mass in Running Order	2,205 kg
Payload	1,045 kg
Towing Capacity (Braked)	3,500 kg
Towing Capacity (Unbraked)	750 kg

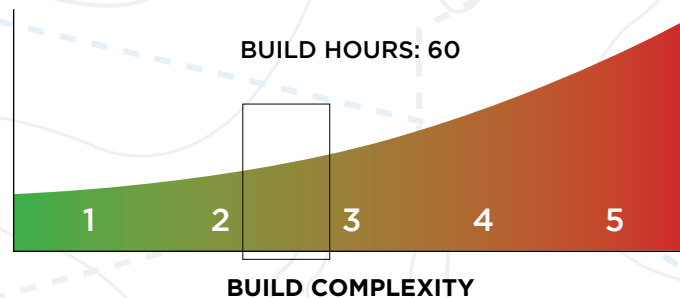
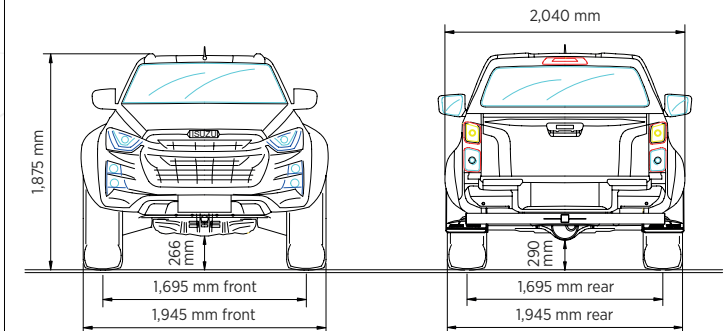
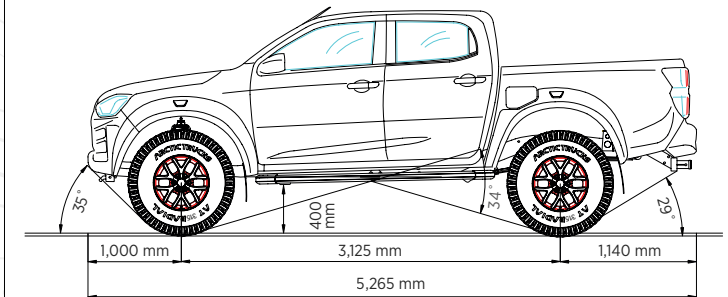

www.arctictrucks.com

*Specification, pricing, weights and dimensions may vary between regions
 **Standard Isuzu spare wheel removed during AT35 conversion